

The exclusive ownership of this drawing is of Eurotermo Srl and in no case does the recipient acquire any rights relating to it. The recipient of the drawing undertakes to maintain maximum confidentiality on the same and not to make any use of it, in whole or in part, that is not previously authorized in writing by Eurotermo Srl. The recipient also undertakes to impose and guarantee compliance with the aforementioned obligations to its employees and / or collaborators, including external ones, by responding to Eurotermo Srl of any violations on their part.

1	2	3	4
Normative / Stds reference UNI EN 13828:2004	Condizioni di utilizzo / Terms of Use		
Compatibilità / Compatibility UBA list	Acqua Pressione massima 10bar Temperatura massima in continuo 70°C Temperatura di picco 90°C Temperatura minima -10°C No SHOCK termico Funzionalità garantita solo a valvola aperta o chiusa, non parzialmente aperta o chiusa	Water Maximum pressure 10bar Maximum temperature in continuous 70°C Peak temperature 90°C Minimum temperature -10°C No thermal SHOCK Functionality is guaranteed only with open or closed valve, not partially open or closed	
Certificazioni / Homologations -			

MARCATURA SUL LATO OPPOSTO
MARKING ON OPPOSITE SIDE

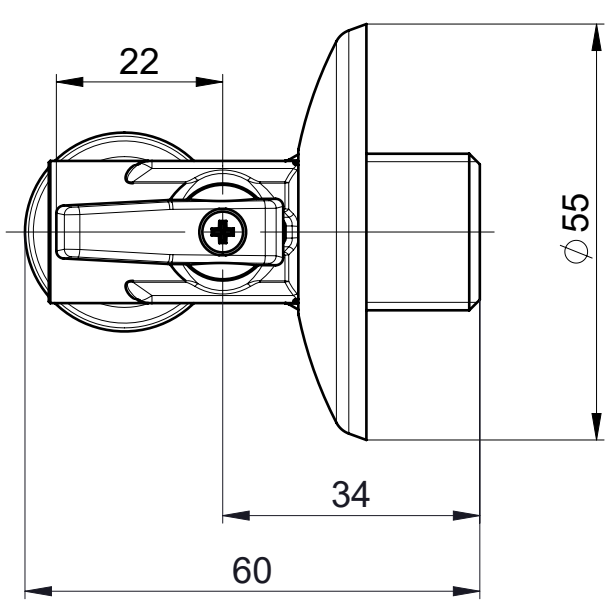
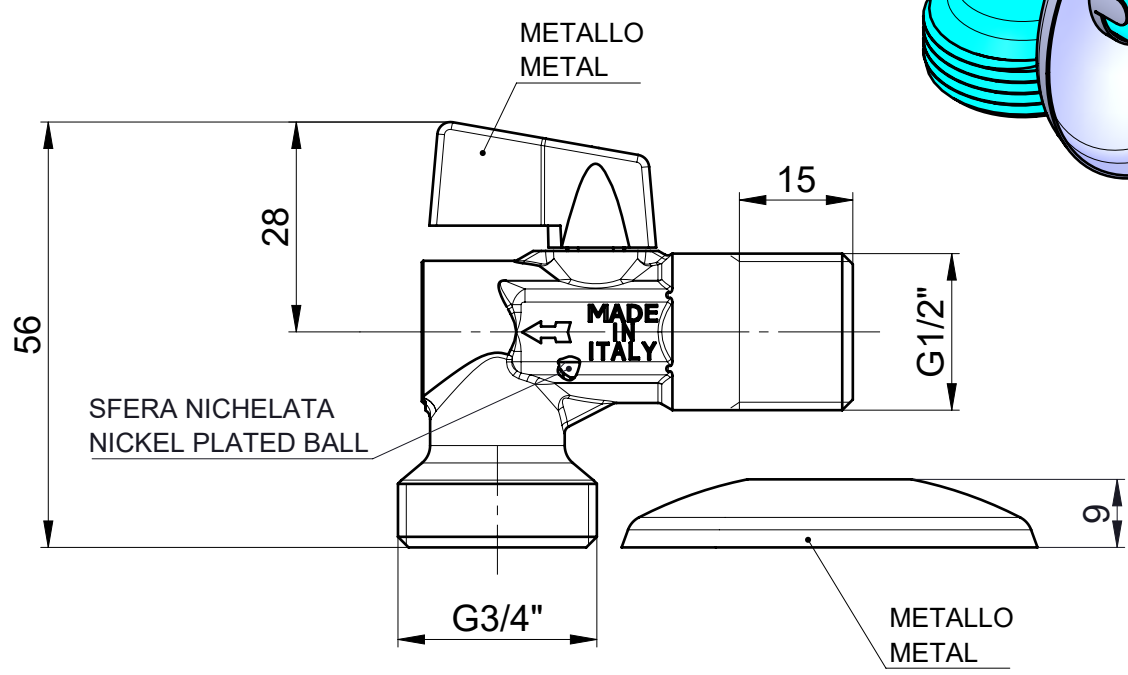
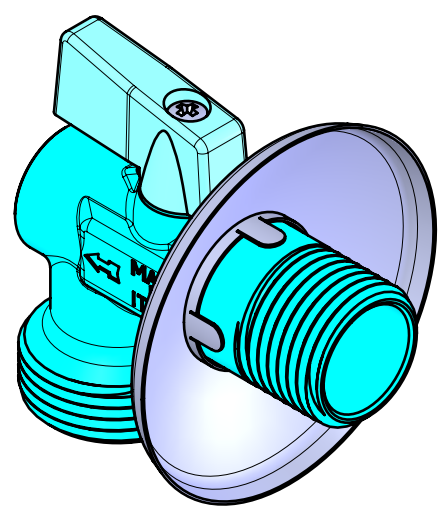
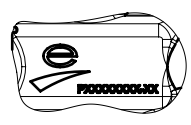

	DISEGNATO/DRAWN S. Murari	DATA/DATE 16/10/2024	APPROVATO/CHECKED M.S.	DATA/DATE 16/10/2024	SCALA/SCALE 1:1	FORMAT A4 Datasheet
	MATERIALE BASE/BASE MATERIAL UNI EN 12165 CW617N-DW	ASPETTO / APPEARANCE CROMATO / CHROME PLATED				
	TENUTA SFERA/SPHERE SEAL NBR 70Sha O-ring	TENUTA ASTA/SPINDLE SEAL NBR 70Sha O-ring				
NUM.DIS/DRAW.-NR. 210010004-DS	DESCRIZIONE/DESCRIPTION VALVOLA A SFERA PER LAVATRICE DN8 G1/2"M x G3/4"M WASHING MACHINE BALL VALVE DN8 G1/2"M x G3/4"M					